

WHY YOU SHOULD INSULATE WITH SPRAY FOAM

TAUNTON'S

# Fine Homebuilding

## Leak-free skylights

Build a stone sitting wall

Must-have electrical tools

Arts & Crafts built-in bench

We test router combo kits

PROJECT GALLERY

Readers' best kitchens and baths

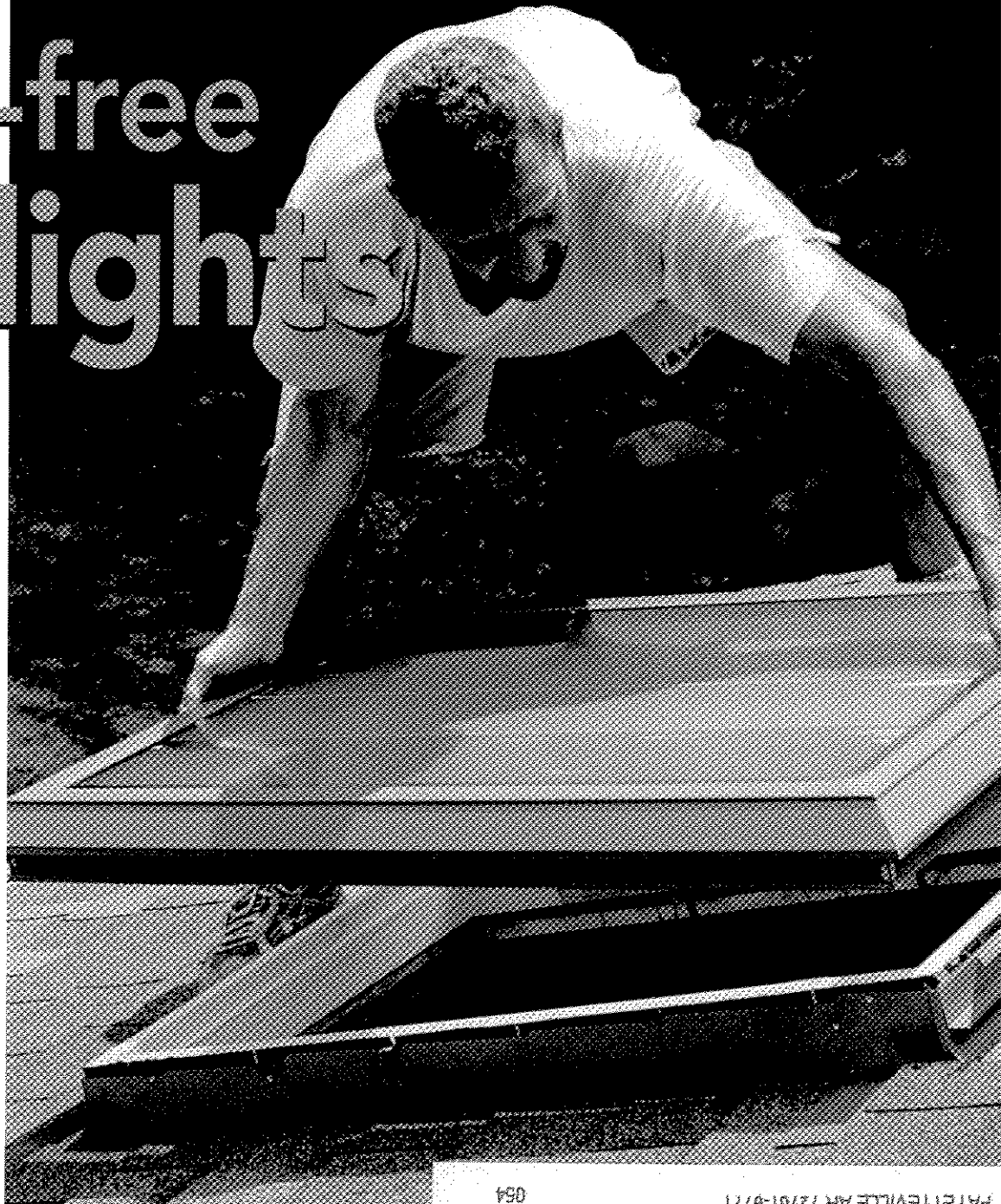

PLUS: Re  
for yo

JULY 2009 NO. 204

www.finehomebuilding.com



U.S. \$7.99/Canada \$8.99

#BXNFYOC \*\*\*\*\*CR LOT 0255A\*\*C-015  
#000110461375/#SAMPLEPH204 P10771  
JENNIFER WILSON  
SAMPLE  
BIOMBASED SYSTEMS  
A  
1475 W/CATO SPRINGS RD  
FAVETTEVILLE AR 72701-6771  
P000227  
129  
054

# To get the full benefit of this superinsulation, you must understand the difference between open- and closed-cell foams, how they perform, and how they're installed.

BY ROB YAGID

I recently spent a day pulling wire with a friend who's an electrician in New York. Late in the afternoon, our conversation turned to a client and friend of his who was seeking advice about insulating her new home. The topic caught the interest of some other guys on site, most from different trades, who gathered around and offered their opinions on which material she should use. After a brief debate, everyone seemed confident that spray foam would yield the best performance. That was until I threw out the question, "Which type?" Sure, they all knew there were two types of spray polyurethane foam, open cell and closed cell, but no one knew enough about them to step up and defend the use of one over the other. The truth is, neither did I.

Spray polyurethane-foam manufacturers have a relatively easy job when it comes to marketing their products because of one key statistic. According to the U.S. Department of Energy, 30% or more of a home's heating and cooling costs are attributed to air leakage. Spray polyurethane foam, or spray foam as it's most often called, is an effective air barrier and significantly reduces energy loss. Combined with a higher thermal resistance (R-value) than most other forms of insulation, it's no wonder spray foam is often

relied on to help make houses ultraefficient. Simply choosing to insulate your home with spray foam doesn't guarantee that it'll perform to its full potential, though. Different climates, construction practices, and wall and roof assemblies benefit from different types of foam. Building codes require specific thicknesses, and proper installation is a must.

## It won't settle and it doesn't off-gas toxic chemicals

Because of the urea-formaldehyde foam used to insulate homes in the 1970s, which could degrade and off-gas unsafe formaldehyde, spray foam is often perceived as being unhealthful and poorly performing. Installers that look as if they're outfitted to survive a nuclear catastrophe perpetuate the misconception that spray foam is toxic.

The fact is that when it's installed properly, spray foam is more physically stable than the studs and sheathing it's adhered to. The oxygen-supplied respirators and head-to-toe protective suits installers wear are necessary only to keep the chemicals that make up spray foam out of their lungs and off their skin during installation.

Spray foam is made of a two-part mixture. The A part is isocyanate, a petroleum-based chemical made by only a handful of companies in the world. The B part contains a catalyst, polyol resin, a surfactant, and a blowing agent. Some manufacturers add flame retardants and colorants to their B component as well.

The blowing agent, a gas that expands the foam's cells to give it volume, receives a lot of scrutiny. Over time, from three months to a year, a portion of the blowing agent in closed-cell foam evaporates into the air. Prior to 2003, chlorofluorocarbon and hydrochlorofluorocarbon blowing agents were in widespread use. These gases are damaging to the atmosphere. The U.S. Environmental Protection Agency has banned the use of those chemicals and recognized the current hydrofluorocarbon (HFC) blowing agent as a safe alternative.

Open-cell foam, which uses water as its blowing agent, emits carbon dioxide as it expands. But manufacturers claim that the amount of carbon dioxide released from the foam has a limited impact on the environment. The Spray Polyurethane Foam Alliance is currently testing this issue.

## The open-cell vs. closed-cell debate

Much of the information you'll find about spray foam is dedicated to its R-value and its permeability. These traits have an overarching impact on the performance of open-cell and closed-cell foams.

In most closed-cell foams, such as those made by Corbond, an HFC blowing agent is captured in the foam's cell structure. This gas has a better thermal performance than the air-filled open-cell foam and gives it a higher overall R-value. However, while HFC-blown closed-cell foam might initially have an R-value as high as R-8 per in., as



**Proper prep yields the best installation.** While spray foam installed by a pro, it's your responsibility to prep the site. Mask windows, electrical boxes, and even floors is important if you want the foam contained to wall, roof, and floor cavities. Anyone during the installation should be outfitted for optimum protection.

# Spray Foam

# What Do You Really Know

## Closed cell

- Density: 2 lb. per cu. ft.
- R-value: 6 per in. (aged)
- Vapor permeability: Semi-impermeable
- Air barrier: Yes
- Blowing agent: Hydrofluorocarbon

## Open cell

- Density: 1/2 lb. per cu. ft.
- R-value: 3.5 per in.
- Vapor permeability: Permeable
- Air barrier: Yes
- Blowing agent: Water

# THERE IS MORE THAN ONE WAY TO USE SPRAY FOAM

## TWO EXPERTS WEIGH IN

Most experts agree that spray polyurethane foam is a revolutionary product. What they don't always agree on is the way it's installed and integrated into a building assembly. To shed some light on this debate, energy-efficient building expert Bruce Harley (Westborough, Mass.) and architect Peter Pfeiffer (Austin, Texas) explain how they use spray polyurethane foam to insulate the homes they build.

### Bruce Harley

Spray foam can be a great material, but understanding its use is often hindered by overeager installers who emphasize the magic rather than the real properties of the products.

Too often, I hear from clients that "my dealer said that I only need 2 in. to 4 in. of foam in my walls because it performs just like R-40 fiberglass and prevents any possible moisture problems." It's just not true. An R-12 wall is an R-12 wall, no matter what the material is. Cutting air leakage saves energy, but it doesn't make up for a low R-value.

For best performance, I use spray foam in a variety of ways when designing the shell of a home. Here's one example.

Bruce Harley of Conservation Services Group is an energy-efficient construction expert and author of *Cut Your Energy Bills Now* (The Taunton Press, 2008).

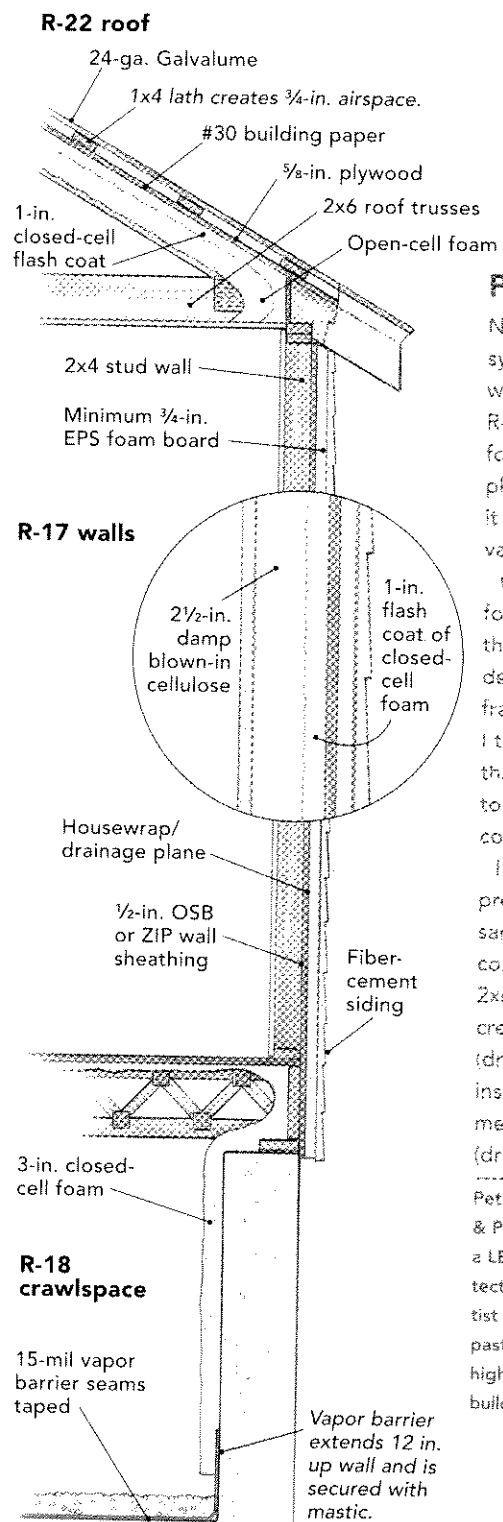
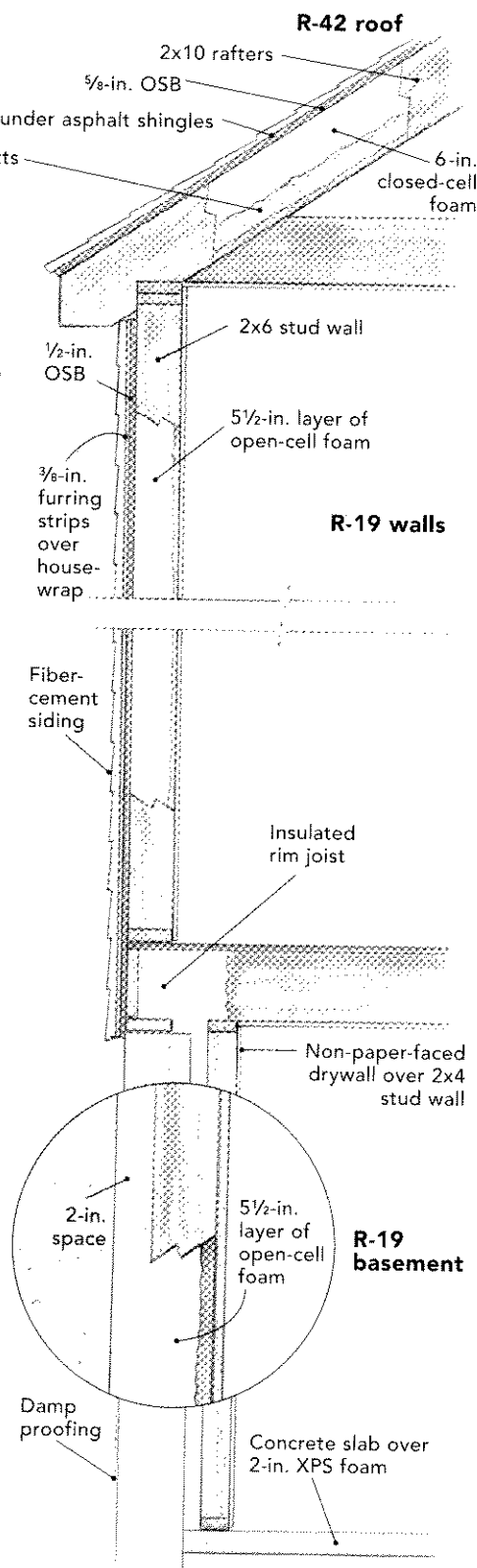

### Peter Pfeiffer

No other insulation system I am familiar with provides the real R-value that spray foam does, accomplishes the air-sealing it does, or thwarts vapor flow as well.

Closed-cell spray foam greatly reduces the chance for condensation within the framing of a home. I think it is critical that houses be built to thwart vapor flow correctly.

I insulate all homes pretty much the same. However, in colder climates, I use 2x6 exterior walls, create a cold roof (drawing p. 36), and insulate the basement or crawlspace (drawing left).

Peter Pfeiffer of Barley & Pfeiffer Architects is a LEED-accredited architect and building scientist who has spent the past 30 years developing high-performance building-design strategies.

the blowing agent evaporates through the cell walls and is replaced by air, its R-value diminishes. Closed-cell foam's "aged" R-value is roughly R-6 per in. Some manufacturers produce water-blown closed-cell foams. These foams have the same performance properties as HFC-blown foam, but slightly lower R-values at around R-5.5 per in.

Closed-cell foam's greater density, 2 lb. per cu. ft. compared with open cell's 1/2 lb. per cu. ft., also increases its R-value and offers it the rigidity that open-cell foam lacks. Tests at the National Association of Home

Builders research center confirmed that closed-cell foam can actually increase the shear strength of conventionally framed walls by 30%. Closed-cell foam also has a low vapor-permeability rating (roughly 0.5 perms at a thickness of 3 in.) and is considered a class-II vapor retarder, meaning that it's semi-impermeable.

Open-cell foam, made by companies such as Icynene and Demilec, has a greater expansion rate than closed-cell foam. It expands 100 times its initial volume (closed-cell foam expands only 30 times its initial volume), so less of the foam is needed to insulate a house. Although both foams will dry if they ever get wet, open-cell foam is vapor permeable and dries much faster than closed-cell foam.

Open cell's one major weakness is its lower R-value, roughly R-3.5 per in. This means that when used in a 2x4 exterior wall, it will create an assembly that's approximately only R-12, which won't meet code in most parts of the country.

### Installing lots of foam isn't as effective as you think

A lot of energy-conscious architects and builders shoot for the highest R-values they can possibly attain: R-40 walls and an R-60 roof. However, R-values aren't necessarily an accurate reflection of overall thermal performance. For example, you would think that an R-40 wall full of spray foam would perform twice as well as a wall sprayed

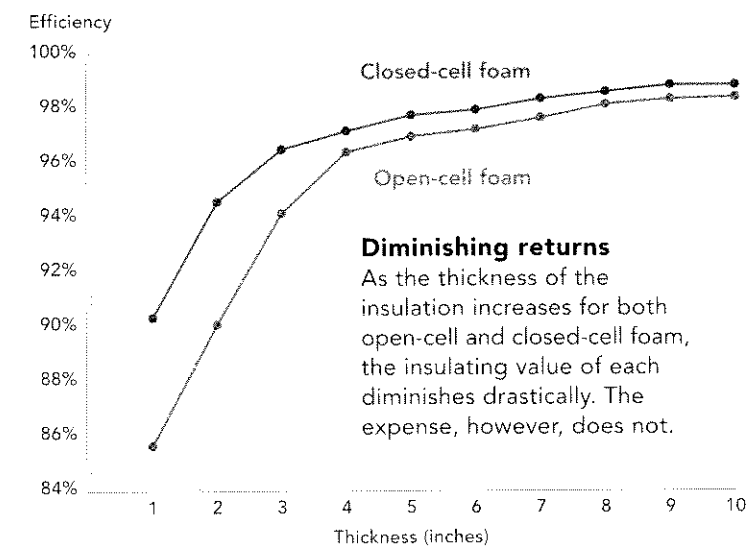

### Diminishing returns

As the thickness of the insulation increases for both open-cell and closed-cell foam, the insulating value of each diminishes drastically. The expense, however, does not.

that of an R-20 wall (not factoring in the construction material to create deeper cavities for the extra foam), it reduces the heat flow through a wall by only an additional 2%. For this reason, Porter says that in most parts of the country, 6 in. of foam—both open or closed cell—is perfectly adequate. Others, like North Carolina builder Michael Chandler ("Prepping for Spray Foam," *ENR* 10/12/08) and online at FineHomebuilding.com, don't feel the same way.

"I want my walls and roof deck to have the highest R-value possible," Chandler says. "If it costs me an additional \$3000 additional 2% in performance, I'm OK with that. If it's going to cost an additional \$7500, well, then I'd have to think about it."

### Thickness limitations ensure fire safety

Foams have two maximum thickness limitations: one for foam in its cured state and one for foam while it's being applied. Each limitation varies based on the manufacturer and the type of foam.

To be code-approved, spray-foam manufacturers have their products tested by the International Code Council Evaluating Laboratory (ICC-ES) for smoke and flame spread. The ICC-ES looks at the burning behavior of a sample of cured foam, which must be at the thickness intended for use. The catch is that most testing facilities can't analyze foam samples greater than 4 in. or

## Spray foam for the eco-conscious

Consuming fossil fuels to make products intended to conserve fossil fuels makes little sense to a lot of people. All spray foams contain a certain level of petroleum in their A component and in their B component. Manufacturers such as BioBased Insulation, Demilec, and Icynene have created more environmentally benign spray-foam products by reducing the amount of petroleum used in their B component. They replace a portion of the polyol resin, which makes up 20% to 30% of the B component, with a renewable resource such as soybean or castor-bean oil. Apex even has a sucrose-based polyol. Manufacturers are also exploring the transition to bean oil or sucrose doesn't alter the look (application photos pp. 36-37) or the thermal performance of open- or closed-cell foam in any way.

The amount of soybean, castor bean, or sucrose found in foam varies by manufacturer, so identifying the "greenest" foam might not be so easy. According to the U.S. Department of Agriculture, only a spray-foam product needs to be made of a renewable resource to be labeled as a bio-based foam. Of course, that doesn't factor in the petroleum fueling the crop-cultivation process.

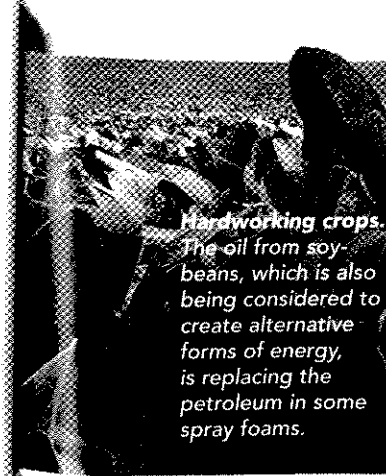

**Hardworking crops.** The oil from soybeans, which is also being considered to create alternative forms of energy, is replacing the petroleum in some spray foams.

## A COLD ROOF FOR COLD CLIMATES

In cold-weather climates, I create a cold roof to prevent ice dams. I do this by installing lath over the top chord, but under the roof deck. This allows the spray foam to encompass the top chord and minimize thermal bridging.

—Peter Pfeiffer

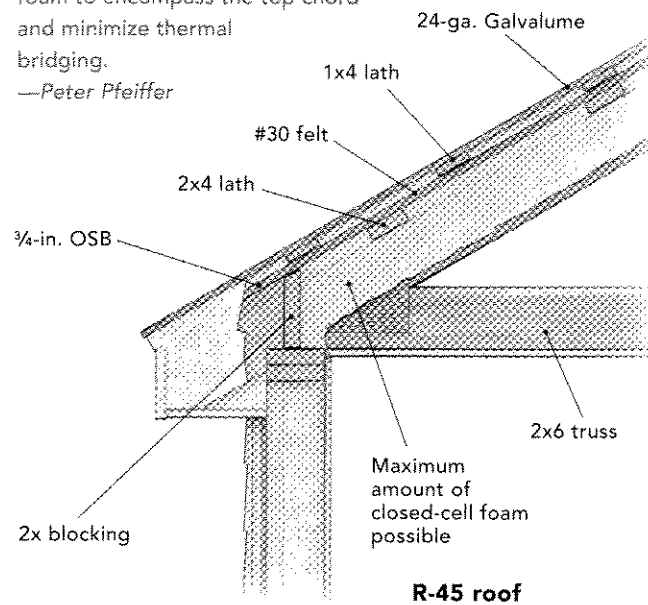

## INSULATE A LEAKY BASEMENT

You may recognize this approach. It's the same one architect Betsy Pettit takes when dealing with a faulty basement wall ("Remodeling for Energy Efficiency," *FHB* #194). An impermeable membrane backed by closed-cell foam channels incoming moisture to a perimeter drain in the floor.

—Bruce Harley

4-in. layer of crushed stone  
Perimeter drain to sump pump

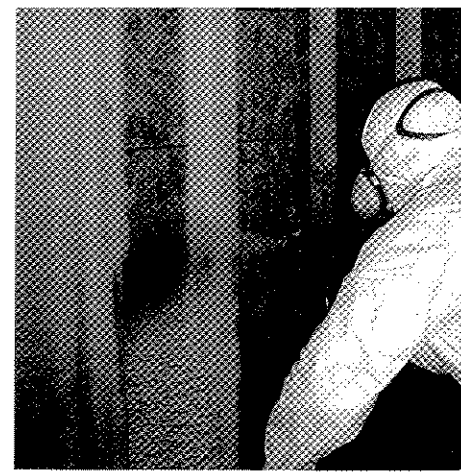
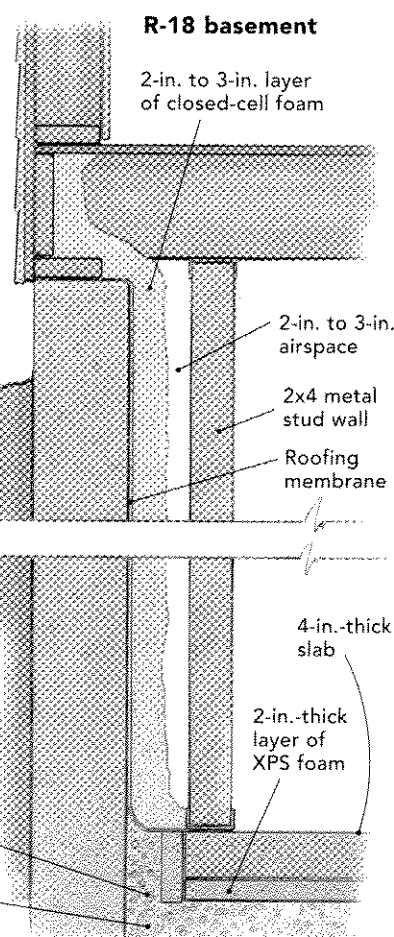

**Keep foam cool.** To prevent spray foam from getting too hot during installation, an installer will likely fill up to 10 stud bays with a 2-in. layer of foam. By the time he reaches the tenth bay, the first bay will be cool enough for a second "lift."

be code-compliant, you can't have foam installed thicker than what's been approved by the ICC-ES. In a lot of homes, 4 in. of foam won't meet insulation standards. Some manufacturers submit even thinner samples for testing because it's easier to pass the smoke and flame-spread test with thinner foam than it is with thicker samples.

Not all spray foam is limited to such thin dimensions, though. Manufacturers have the option of putting their foam through a full-scale test, which is equally recognized by the ICC. Full-scale tests look at foams in thicknesses up to about 12 in. Not every manufacturer takes advantage of this option because testing is very expensive and not all foams will be able to meet the requirement.

To get the insulating value you want in a code-compliant manner, contact the foam's manufacturer and request their evaluation-service report. More often than not, it's available on their Web site and can be found under sections that address ASTM E84, the smoke and flame-spread requirement.

Manufacturers also specify how much foam can be sprayed into a cavity at a single time. In general, open-cell foam doesn't have an application limitation and can be used to fill a cavity in a single pass. Closed-cell foam, however, must be applied in several passes, called "lifts."

Both foams are cured by an exothermic reaction, but closed-cell foam creates a greater amount of heat as it cures and demands proper cooling time before more foam can be added to it. Jim Anderson, the manager for applications and training at BASF, says, "We train our installers to spray closed-cell foam in 2-in.-thick layers and allow them to cool adequately before subsequent lifts. At 2 in., the core temperature of our foam is around 130°F to 150°F, which we feel is a safe level." Anderson adds that there is a real danger to applying too much foam at once. "Deep applications of foam can create extremely high temperatures within the core of the insulation. Not only can the structure of the foam degrade and actually char, which will adversely affect performance, but elements within the cavity like plumbing runs, electrical wires, and boxes can also become damaged."

### Be on site to be sure the job is done right

Most manufacturers have extensive training programs for their installers to be sure that their spray foam is installed safely and correctly. More often than not, installers can be left alone to get the job done. But if you want to stand by and watch as the foam flies, there are a few things to look for to be sure the job is going as it should.

Anderson recommends making a simple depth gauge out of wire to check foam thicknesses. He also says to be aware of off-ratio mixes in the foam, where the A and B components are unbalanced. He adds, "There should be a uniform color within each cavity. If there is a

really dark spot in the wall, it's likely because the foam is A-rich. If the wall appears extra soft and sticky, it's most likely B-rich. Off-ratio mixes can hinder the performance of the foam, and installers are trained to cut out these areas and respray them."

Also, because the expansion rate of closed-cell foam is less severe than open-cell foam, it's easier to fill cavities with minimal excess. Still, qualified installers should be able to fill a cavity evenly whether they're spraying open- or closed-cell foam. Any excess will be cut flush with the studs and thrown away. Keep in mind that spray foam lasts forever, even in landfills.

A spray-foam installation isn't truly complete until a code-required thermal or ignition barrier has been installed over the foam. A thermal barrier, typically 1/2-in. drywall, needs to be installed over the foam in all living spaces. In attics and crawlspaces that are accessed only by service utilities, an ignition barrier—which can be a spray-applied chemical, 1 1/2 in. of mineral wool, or 3/8-in. drywall—can be installed.

### All spray foam is not created equal, according to some

Neal Ganser, president of Corbond, says, "There are a lot of players in the spray-foam game, and they're not pushing the same product, no matter what they say. If you ask a manufacturer what makes their foam different from anyone else's and they don't give you a laundry list of reasons, be alarmed."

However, Ed Pentz, a sales technical manager at CertainTeed, says, "Spray foam is spray foam, and what's in one company's tank is really no different from what's in another's."

One factor that is sure to sway your purchasing decision is the cost of the foam. Spray foam is priced based on board feet. Manufacturers don't price their product. Instead, cost is determined by installers. The spray-foam market is extremely competitive, and spray-foam prices can be astonishingly inconsistent. Michael Chandler recommends getting as many bids as possible. "I've received quotes from \$6800 to \$13,500 for the same exact job," Chandler says. "Prices vary so much, that it may actually pay to have a truck drive two hours to do the job rather than have the local guy spray it." The message: Search far and wide for the installer that suits your needs and your budget. □

Rob Yagid is an associate editor at *Fine Homebuilding*.



**Sloppy installation creates unneeded waste.** A properly filled wall (right stud bay) still has a bit of waste after the foam is trimmed flush with the studs. However, the far bay is filled with too much foam, most of which will end up in the landfill.

## SOURCES

Although this is not a complete list of spray-foam manufacturers, it is representative of the larger national companies. For assistance in finding a spray-foam insulation contractor, visit the Spray Polyurethane Foam Alliance at [www.sprayfoam.org](http://www.sprayfoam.org).

Apex Foam Industries [www.apexfoam.com](http://www.apexfoam.com)  
BASF [www.basf.com](http://www.basf.com)  
BioBased [www.biobased.net](http://www.biobased.net)  
CertainTeed [www.certainteed.com](http://www.certainteed.com)  
Chemical Design [www.chemicaldesigncorp.net](http://www.chemicaldesigncorp.net)  
Corbond [www.corbond.com](http://www.corbond.com)  
Demilec [www.demilecusa.com](http://www.demilecusa.com)  
Foametix [www.foametix.com](http://www.foametix.com)

## Can I retrofit my home with foam?

If you want to improve the efficiency and comfort of your home but are not willing to gut your house to install conventional spray foam, you have another option. Manufacturers including Icynene and Demilec make foam products to insulate existing walls. An installer drills several holes in the walls or ceilings and pumps foam into the cavity. The foam compresses existing fiberglass batts and air-seals through-wall penetrations. The foam, which is most often an open-cell product and referred to as a pour-in place or a pour-fill system, expands in the path of least resistance, so it won't blow out the drywall. This type of application is more laborious than a conventional installation. Also, the material has a lower yield, so the retrofit process is often much more expensive.

Not all thermal improvements have to be so grand or have to be so expensive. Manufacturers such as Fomo and Dow produce one-use cans of spray foam perfect for air-sealing window and door-frame openings. For larger projects, such as air-sealing rim joists or stud bays prior to using other insulation, manufacturers such as Tiger Foam and RHH Foam produce two-part do-it-yourself kits that yield up to 650 sq. ft. of coverage at 1-in. thickness. Single-use cans cost roughly \$5, and larger kits cost between \$300 and \$500.

